

| REV | MARK | ECN NO. | DESCRIPTION | NAME | DATE |
|-----|------|---------|-------------|------|------------|
| A0 | | | | | 2016/03/01 |

SPECIFICATIONS :

MATERIAL :

- HOUSING MATERIAL: (1) GLASS FILLED PA66 (UL94V-0), (2) GLASS FILLED PA46 (UL94V-0), (3) GLASS FILLED PBT (UL94V-0).
- CONTACT MATERIAL: PHOSPHOR BRONZE $\Phi 0.46\text{MM}$.
- PLATING: GOLD PLATING Fu^{-} -50u" OVER NICKEL.

ELECTRICAL :

- VOLTAGE RATING: 125V_{vac} RMS .
- CURRENT RATING: 1.5AMP .
- CONTACT RESISTANCE: 30m Ω MAX .
- INSULATION RESISTANCE: 500M Ω MIN @ 500V_{dc} .
- DIELECTRIC WITHSTANDING VOLTAGE: 1000V_{vac} RMS 50Hz 1MIN.

MECHANICAL :

- DURRABILITY : 750 CYCLES MIN.
 - INSETION FORCE: 2.2Kgf MAX.
 - RETENTION STRENGTH : 7.7Kgf MIN BETWEEN JACK AND PLUG.
- ENVIRONMENTAL :
- STORAGE TEMPERATURE : -40° C TO 85° C.
 - OPERATION TEMPERATURE : -40° C TO 70° C.

PC Board Layout

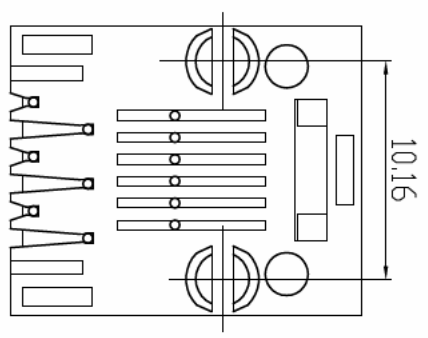
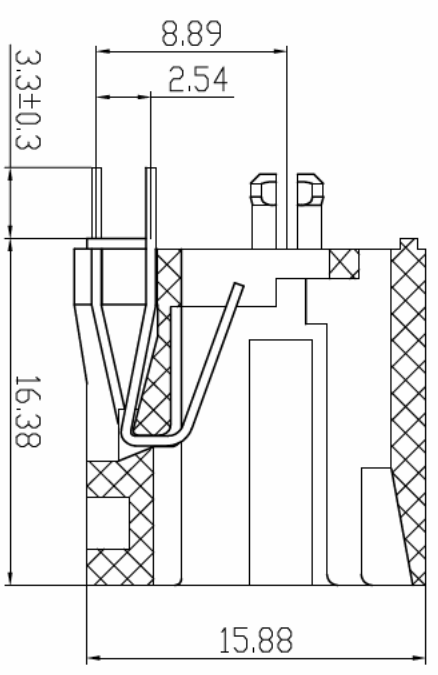
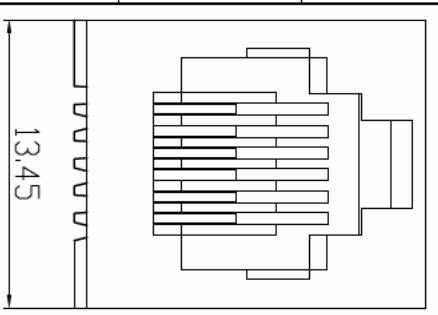
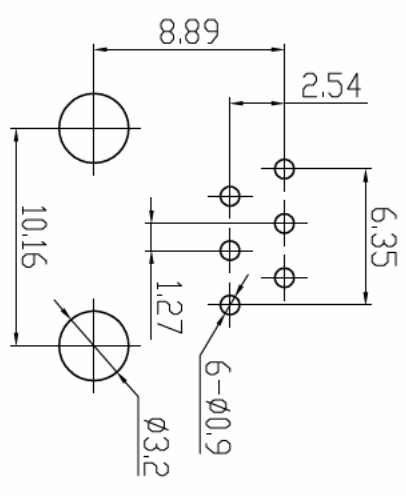

| TOLERANCE UNLESS OTHERWISE SPEC | | DESIGNED | SIZE | TITLE : |
|---------------------------------|-----------|--------------|--------|---------------------------|
| BASIC DIMENSION | TOLERANCE | CHECKED | UNIT | PART NO. : SM C04 5222 66 |
| .X | ± 0.25 | STANDARDIZED | MM | DRAWING NO. : |
| .XX | ± 0.15 | APPROVED | SCALE | |
| .XXX | ± 0.05 | | 1:1 | |
| ANGLES | ± 0.5° | | WEIGHT | |
| | | | SHEET | |
| | | | 第1页共1页 | |
| | | | REV | |
| | | | A | |