

1

2

3

4

5

6

7

8

A

B

C

D

E

F

G

H

A

B

C

D

E

F

G

H

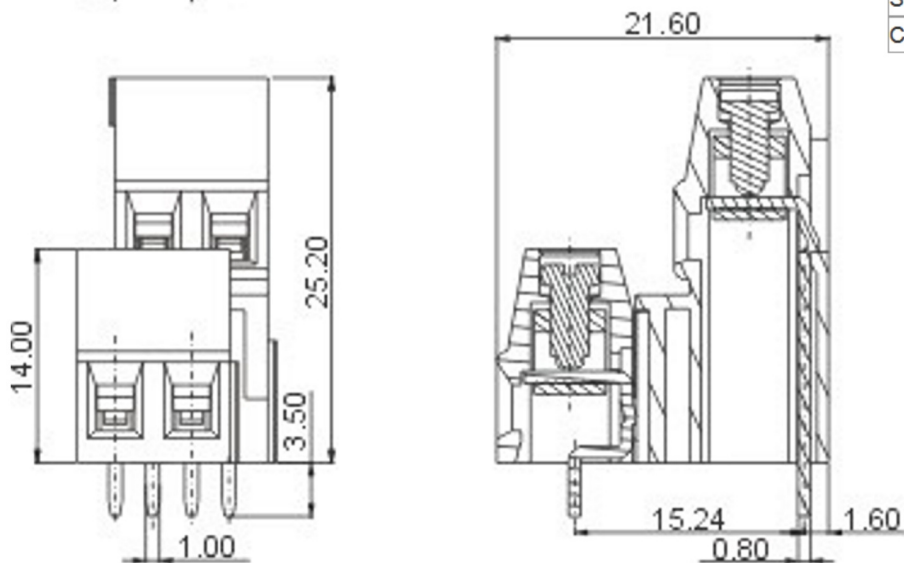
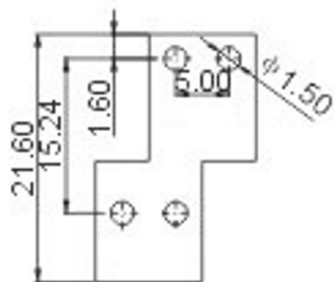
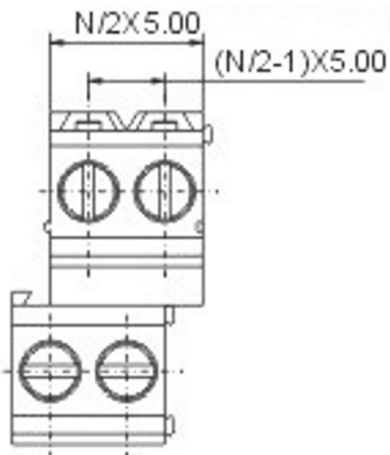

Standard	UL	VDE
Rated voltage	300V	250V
Rated current	15A	18A
Wire range	24-12AWG	2.5mm ²
Withstanding voltage	AC2000V/1Min	
Ambient temperature	-40°C~+105°C	
Strip length	7mm	
Torque	0.4Nm(3.5Lb-In.)	
Pitch	5.00 / 5.08mm(.197")	
Poles	2P , 3P ---Any poles	
Housing	PA66,UL94V-0	
Screws	M2.5,steel,Cr ³⁺ Zn plated	
Solder Pins	Brass, Tin plated	
Contact Cage	Brass, Ni plated	



RoHS
Compliant

SCHMID-M

APPD.

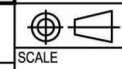

SCALE

TOLERANCE

.0 ±
.00 ±
ANG. ±
SIZE.

PART NAME

Terminal Block, Screw Clamp Style, Hor. Cond.,
Pitch 5,00mm, PCB Straight,
XX..... Nr. Pins

DWG.

GRAY

UNIT

M M

A 4

DATE

2014/01/30

PAGE

1 OF 1

REV.

A

PART NO.

SM C09 15010 XX SS4-B

1

2

3

4

5

6

7

8