

1

2

3

4

5

6

7

8

A

B

C

D

E

F

G

H

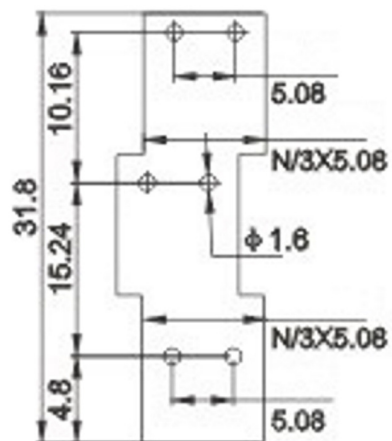
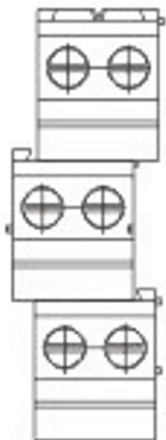

Standard	UL	VDE
Rated voltage	300V	250V
Rated current	15A	18A
Wire range	24-12AWG	2.5mm <sup>2</sup>
Withstanding voltage	AC2000V/1Min	
Ambient temperature	-40°C~+105°C	
Strip length	7mm	
Torque	0.4Nm(3.5Lb-In.)	
Pitch	5.00 / 5.08mm(.197")	
Poles	2P , 3P ---Any poles	
Housing	PA66,UL94V-0	
Screws	M2.5,steel,Cr <sup>3+</sup> Zn plated	
Solder Pins	Brass, Tin plated	
Contact Cage	Brass, Ni plated	

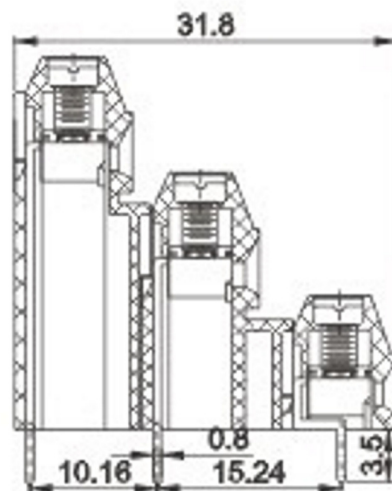
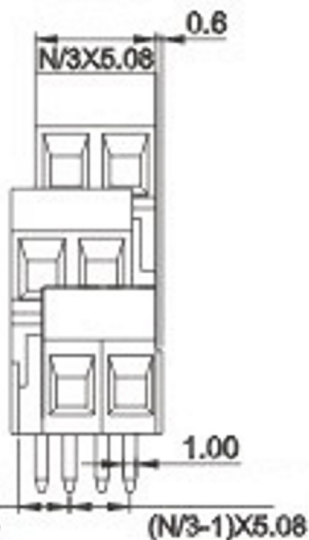

RoHS Compliant		<b>SCHMID-M</b>	
APPD.	SCALE	TOLERANCE	PART NAME
DWG. GRAY	UNIT M M	.0 ± .00 ± ANG. ±	Terminal Block, Screw Clamp Style, Hor. Cond., Pitch 5,08mm, PCB Straight, XX..... Nr. Pins
DATE 2014/01/30	PAGE 1 OF 1	SIZE A 4	PART NO. SM C09 15810 XX SS4-A3

1

2

3

4

5

6

7

8